

The New **Ready Van II** 132" body for dual wheel cutaway chassis, available with 64" or 74" interior heights

There's more to this Ready Van than merely a new size. The new Ready Van II offers a combination of standard features that simply cannot be matched by any other manufacturer. Reading exclusives like a powder coat finish, and Latch-Matic® come standard, as do rear drop down doors, a radius contour on the front bulkhead, and smooth steel sides. A black powder coated bumper (not installed) also comes standard.

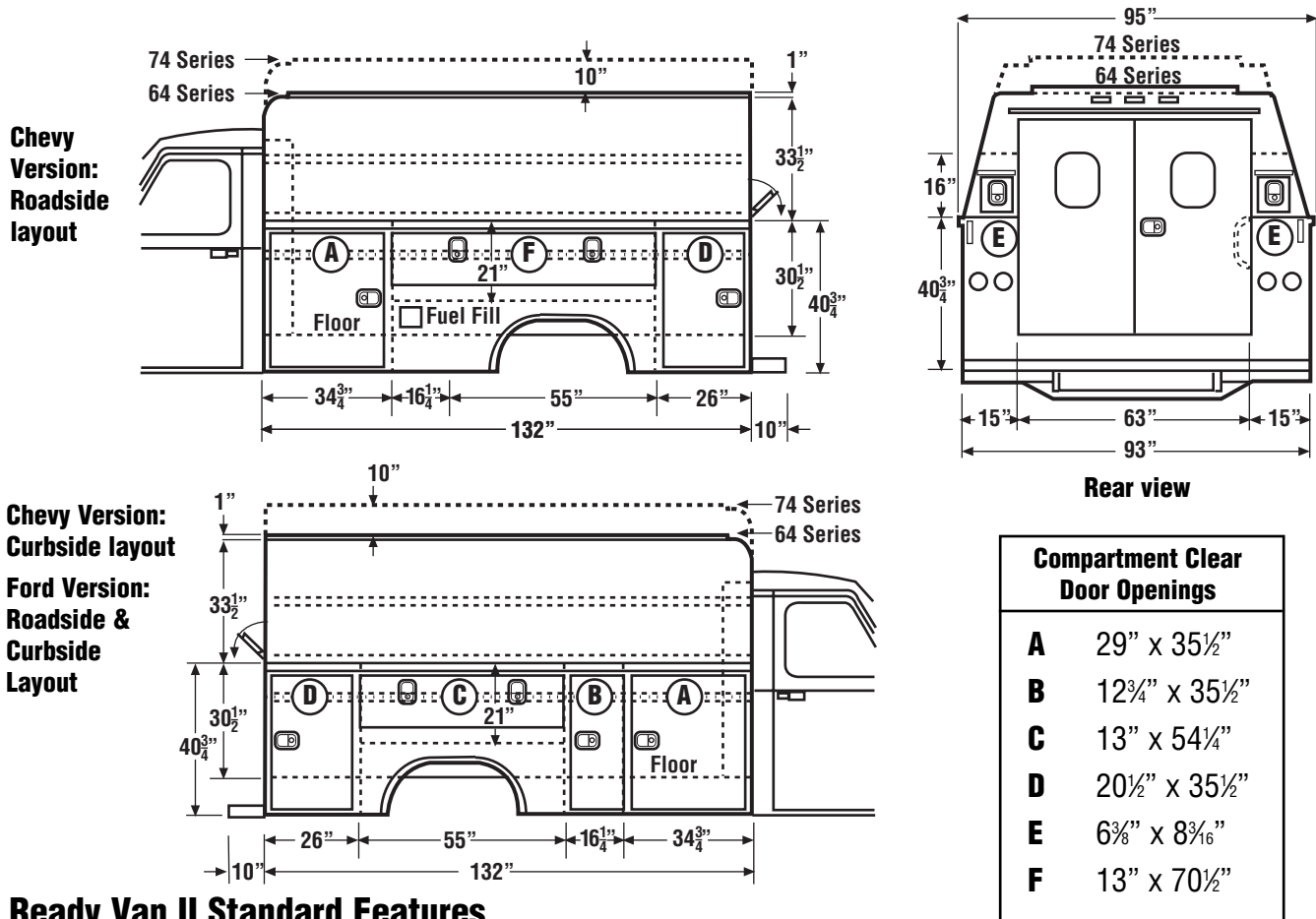

Ready Van II Standard Features

- 132" length and 95" width
- 63" x 56¼" (64 series) & 63" x 61¼" (74 series) rear opening
- Sides are tapered and smooth to provide a clean "billboard" surface for owner-applied graphics
- A white powdercoat finish (inside and out)
- Rear windows protected with steel screens inside compartment area
- (2) full length shelves inside cargo enclosure, each side
- (2) drop down access doors (1 per side) at rear of body for storage of 10' lengths of pipe or conduit
- Solid front side panels & center solid sliding door with window.
- Equipped with Latch-Matic® advanced remote wireless locking system for side doors & rear superstructure doors. NOTE: (2) small rear drop-down doors are not Latch-Matic equipped
- Side and rear vertical doors equipped with nitrogen gas props to hold doors at 90°
- Interior features (2) dome lights with switch at rear and (1) grab handle
- Roadside horizontal compartment opens into floor area
- Drop step poached rear bumper, powder coated black (not installed)
- Factory installed stripes & graphics
- **Equipped with "Classic II™" features**
 - A-60 galvanized steel construction
 - Acrylic E-coat primer protected
 - Advanced rotary locking system with stainless steel paddle locks
 - Dual Pro® seal provides two levels of protection against the elements
 - Thicker, heavier gauge compartment doors
 - Stainless steel bolt-on brackets
 - Understructure is completely undercoated
 - Light guards in rear compartments

EXPECT MORE. CHOOSE READING.



(800) 458-2226
www.readingbody.com